

Instruction Sheet

Kit Number: 79223300

BAGGER COMPLETION KIT – 72" DECK



WARNING: FAILURE TO FOLLOW INSTRUCTIONS could result in personal injury and/or damage to unit.
Read, understand, and follow all safety practices in Operator's Manual before beginning.

NOTICE: Refer to the bagger Operator's Manual for additional installation instructions.

Package Contents

Check the contents of your kit for the parts listed below. Also see Figure 1.

Item	Description	Qty	AriensCo P/N
1	Hex Belt	1	07200911
2	Bagger Discharge Bracket	1	09389151
3	5/16"-18" x 3/4" Round Head Square Neck Bolt	1	06200309
4	5/16"-18" Center Locking Flange Nut	1	06500840
5	Right Belt Cover	1	09394251
6	Rubber Grommet	3	07500429
7	1/4"-20 Threaded Ball Stud	2	05275900
8	Double Pulley	1	07341600

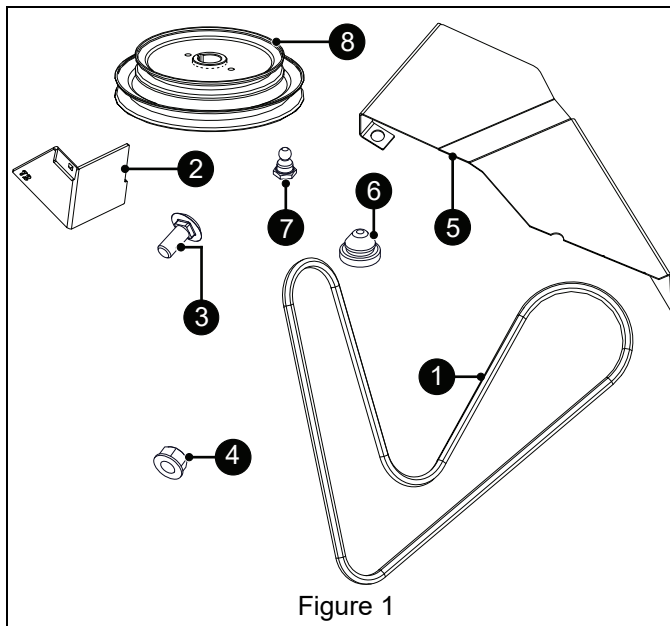

Figure 1

INSTALLATION

1. Stop engine, remove key and engage parking brake. Wait for moving parts to stop and for hot parts to cool.
2. Disconnect spark plug wires.
3. Remove hardware from front of blower housing outlet. Discard hardware. See Figure 2.

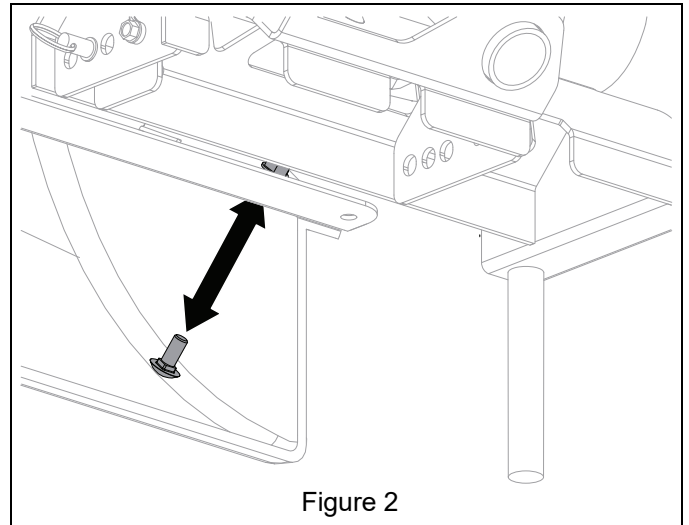

Figure 2

4. Install bagger discharge bracket (item 2) in front of blower housing outlet. Secure with one 5/16" x 3/4" round head square neck bolt (item 3) and one 5/16" center locking flange nut (item 4). See Figure 3.

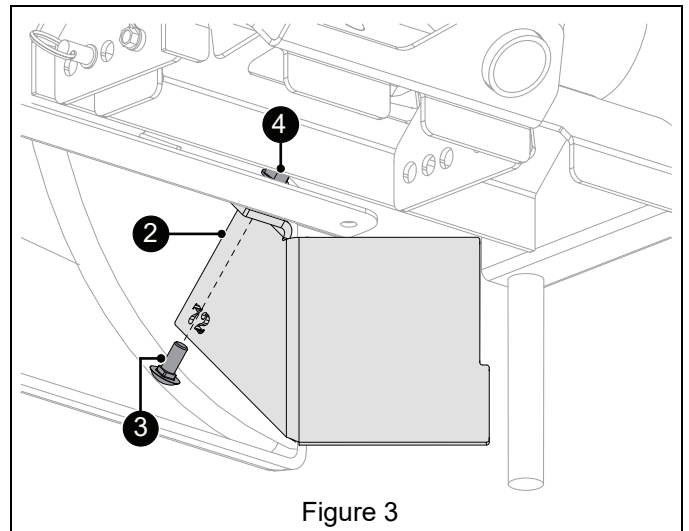
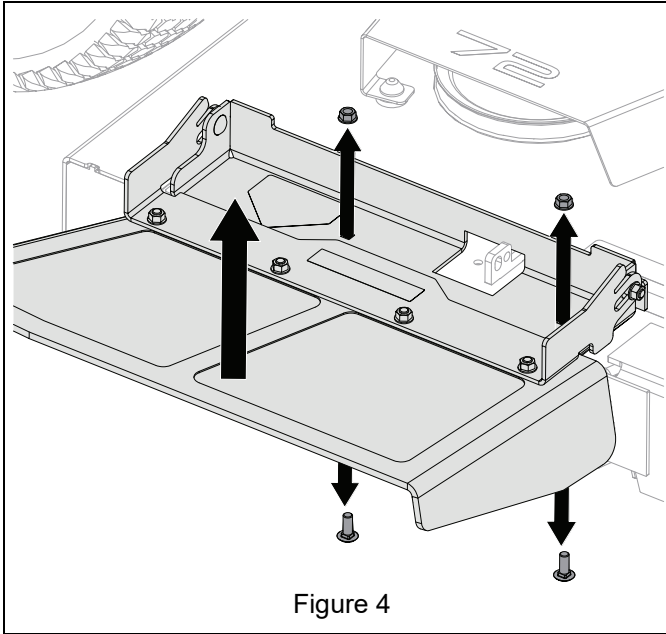
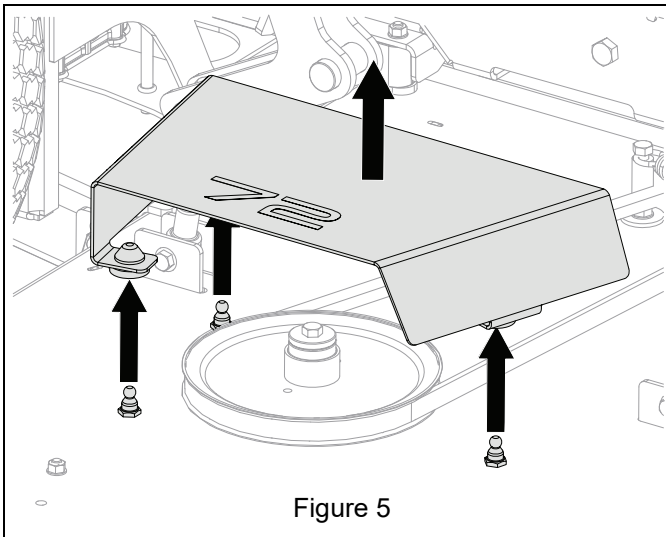

Figure 3

5. Remove and retain hardware securing discharge chute to mower deck. Remove chute and retain for operation without bagger. See Figure 4.



6. Remove belt cover from mower deck. Retain for operation without bagger. See Figure 5.



7. Insert three rubber grommets (item 6) into holes in belt cover (item 5). See Figure 6.

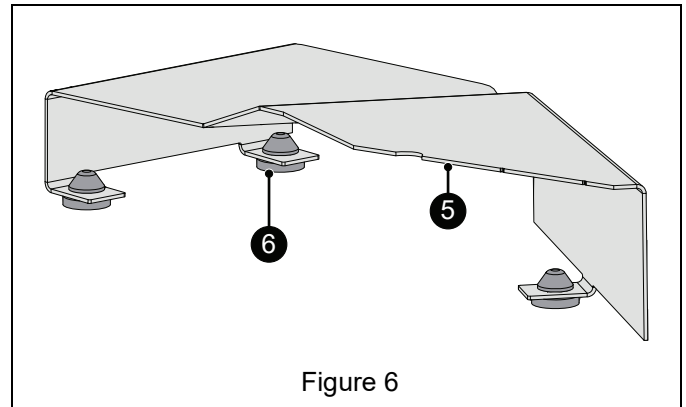

8. Remove two hex nuts and round head square neck bolts from top of deck. Retain bolts; dispose of nuts. See Figure 7.

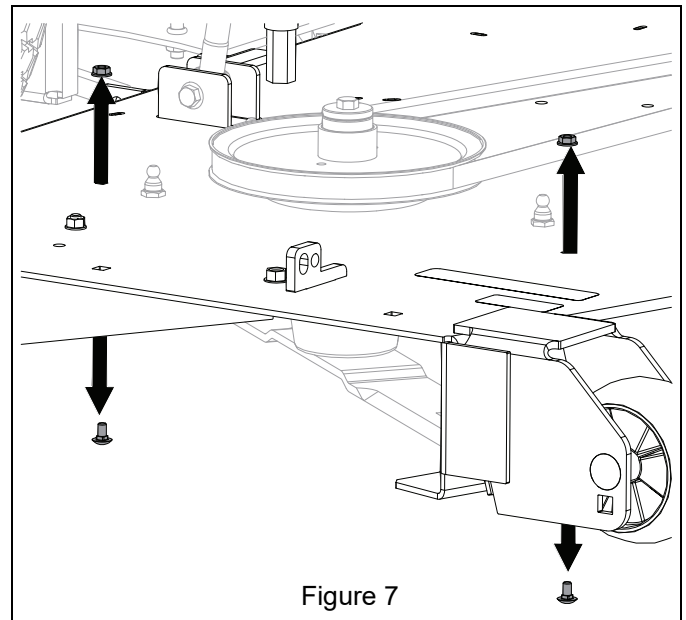

9. Attach two threaded ball studs (item 7) to deck using bolts just removed. See Figure 8.

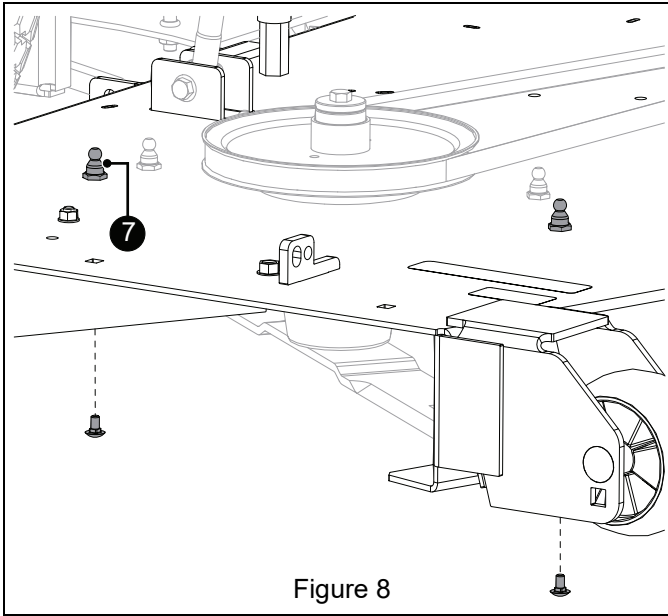

Figure 8

See Figure 9.



CAUTION: Use care when releasing idler spring tension. Keep body parts away from idlers when performing this operation.

10. Slowly remove spring hook from anchor bolt to release tension from belt idler.
11. Remove and retain V-belt.

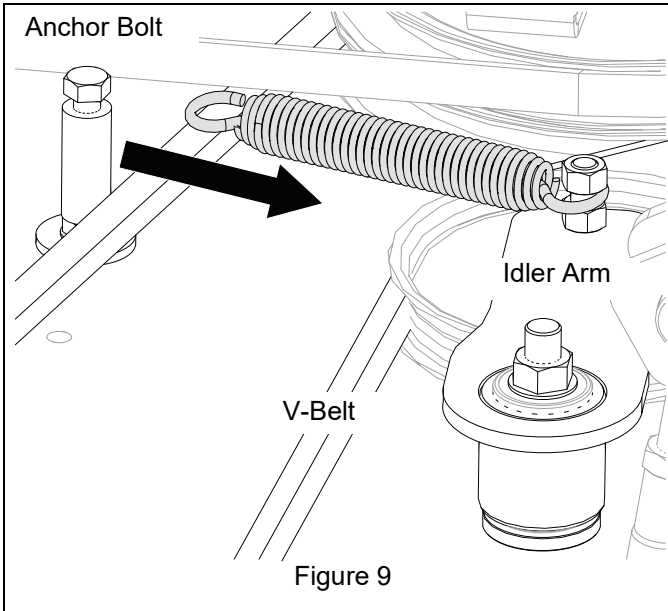

Figure 9

12. Remove and retain hardware from right deck pulley. Remove pulley and retain for operation without bagger. See Figure 10.

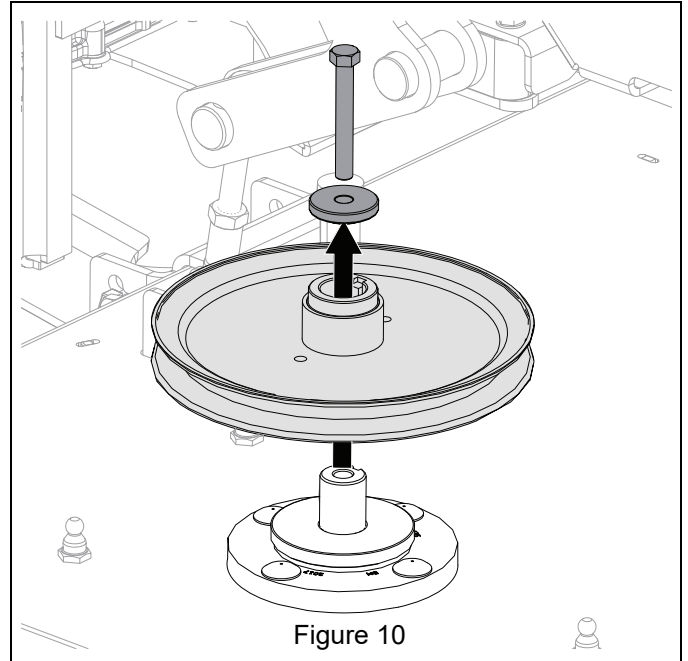

Figure 10

13. Install double pulley (item 8) onto spindle housing using hardware just removed. Torque spindle pulley mounting bolt to 55.6 N•m – 66.4 N•m (41 lb-ft – 49 lb-ft). See Figure 11.

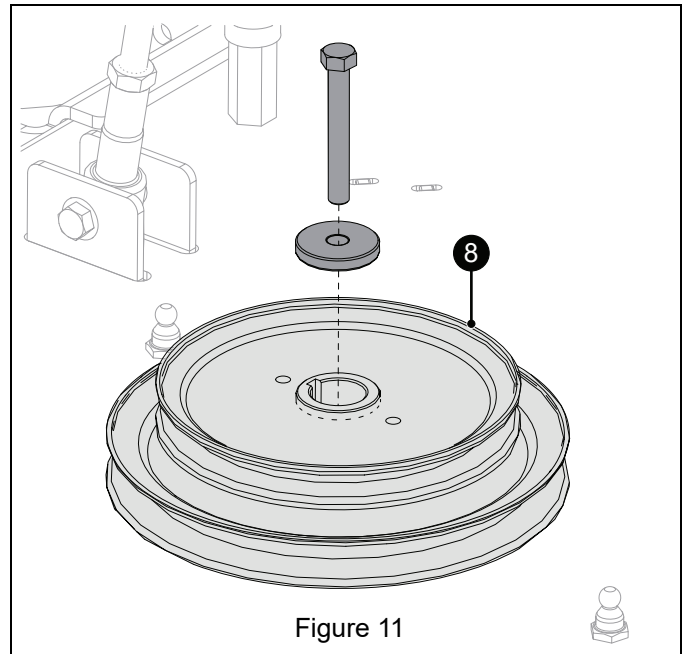
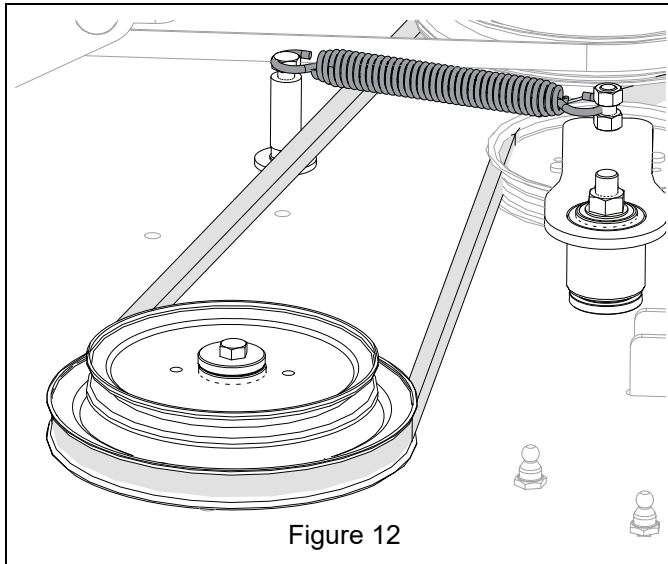

Figure 11

See Figure 12.

14. Install V-belt around double pulley.

15. Reinstall idler spring hook around anchor bolt to apply tension to belt.



19. Install belt cover. See Figure 14.

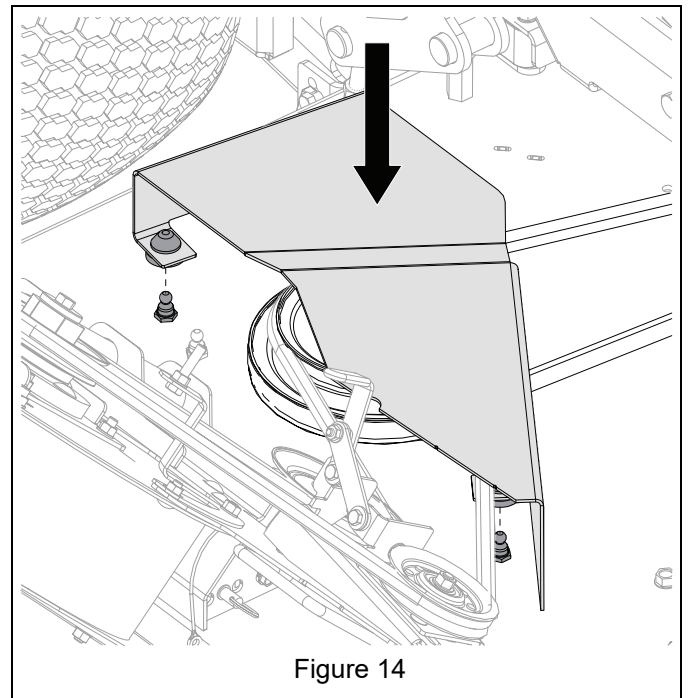

See Figure 13.

16. Install blower assembly onto mower deck. Refer to bagger Operator's Manual for instructions.

17. Install hex belt (item 1) onto blower and double pulley in the following order:

- a. Around split pulley
- b. Around front idler pulley (back side of belt should contact back idler pulley)
- c. Around upper pulley of double pulley

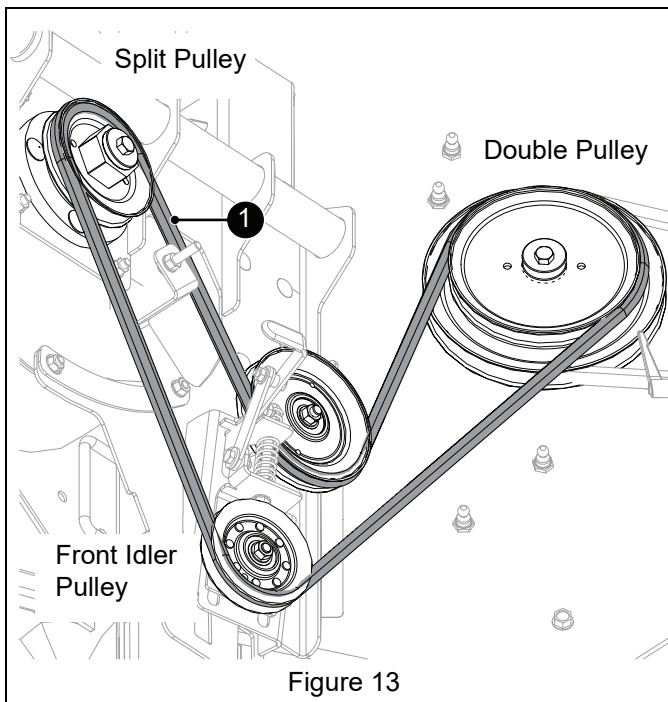

20. Install blower cover onto bracket and secure with one 1 1/2" washer and one knob from bagger kit. See Figure 15.

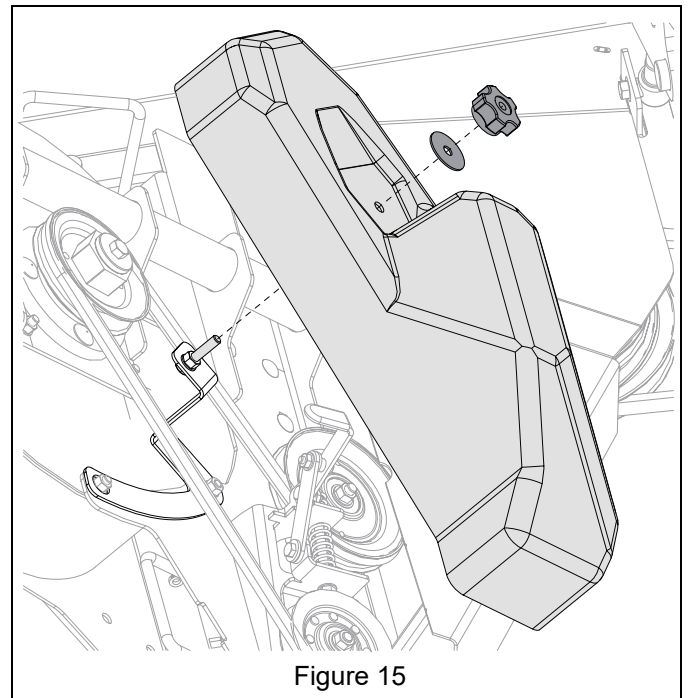

21. Refer to bagger Operator's Manual for remaining installation and operation instructions.

22. Reconnect spark plug wires.

18. Adjust belt tension. Refer to bagger Operator's Manual for instructions.